

- 1. Material/Plated
  - 1.1 Housing: High temperature thermoplastic, Black UL 94V-0.
  - 1.2 Cover: High temperature thermoplastic, Black UL 94V-0.
  - 1.3 Terminal: Copper Alloy, Gold Flash Plated At Contact Area, Gold Plated At Soldered Area, Nickel Underplated Overall
  - 1.4 Shell: Stainless steel, Nickel plated Overall
  - 1.5 Out Shell: Stainless steel, Nickel plated Overall
  - 1.6 Ring: Silicon
  - 1.7 Epoxy: Epoxy, Black
- 2. Electrical Performance
  - 2.1 Rated Voltage: 30V AC
  - 2.2 Rated Current: 1, 5Pin: 3.0A Max. 2, 3, 4Pin: 1.0A Max.
  - 2.3 Contact Resistance: 30mΩ Max.
  - 2.4 Insulation Resistance: 100MΩ Min.
  - 2.5 Dielectric Strength: 100V AC
- 3. Mechanical Performance
  - 3.1 Insertion Force: 35N Max.
  - 3.2 Withdrawal Force: 8-35N
  - 3.3 Durability: 10000 Cycles
- 4. Operating Temperature: -25° C To +85° C
- 5. Waterproof: IPX8

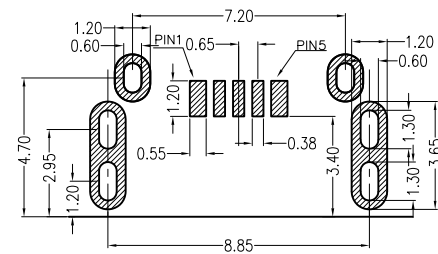
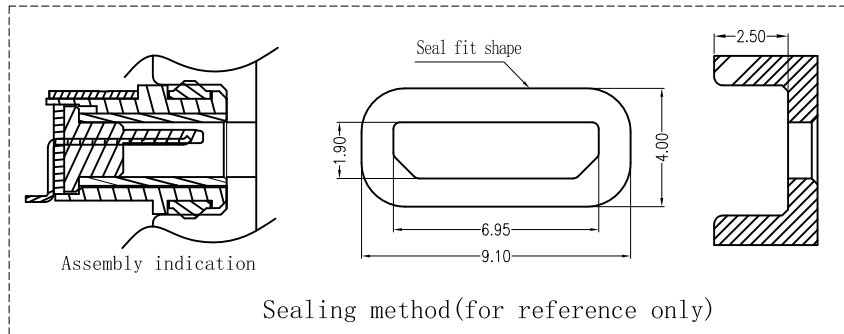
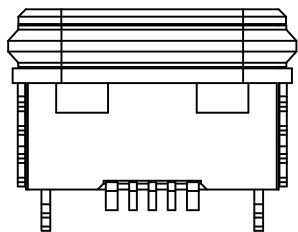

RECOMMEND PCB LAYOUT

					DRAWN	Tom	2018-06-13	DIMENSION TOLERANCE X ±0.35 X.X ±0.25 X.XX ±0.15 GENERAL ANGLE: ±3° UNIT: mm
					CHECKED	Ango	2018-06-13	
					APPROVE	Kevin	2018-06-13	
					SCALE: N/A	SHEET: 1 OF 1		
A	NEW RELEASE		Tom	2018-06-13				
REV.	DESCRIPTION	ECN NO.	NAME	DATE				
<b>REVISIONS</b>								

**东莞市实邦电子有限公司**  
**IDSTRB ELECTRONIC CO., LTD**

TITLE	Micro USB B 5P Waterproof DIP
PART NO.	UMX-023H1AP
DWG. NO.	